

PARTS LIST						
ITEM	QTY	PART NO.	PART DESCRIPTION	LENGTH	UNIT WT.	NET WT.
1	1	X-CSRT-PCBW	PIPE CONNECTION BRACKET WIDE	14 in	8.99	8.99
2	2	G1202	1/2" x 2" HDG HEX BOLT GR5	2 in	0.18	0.35
3	2	X-UB1300	1/2 X 3" X 5" X 2" U-BOLT	5 in	0.74	1.48
4	4	G12FW	1/2" HDG USS FLATWASHER	3/32 in	0.03	0.14
5	6	G12LW	1/2" HDG LOCKWASHER	1/8 in	0.01	0.08
6	6	G12NUT	1/2" HDG HEAVY 2H HEX NUT		0.07	0.43
					TOTAL WT. #	11.47

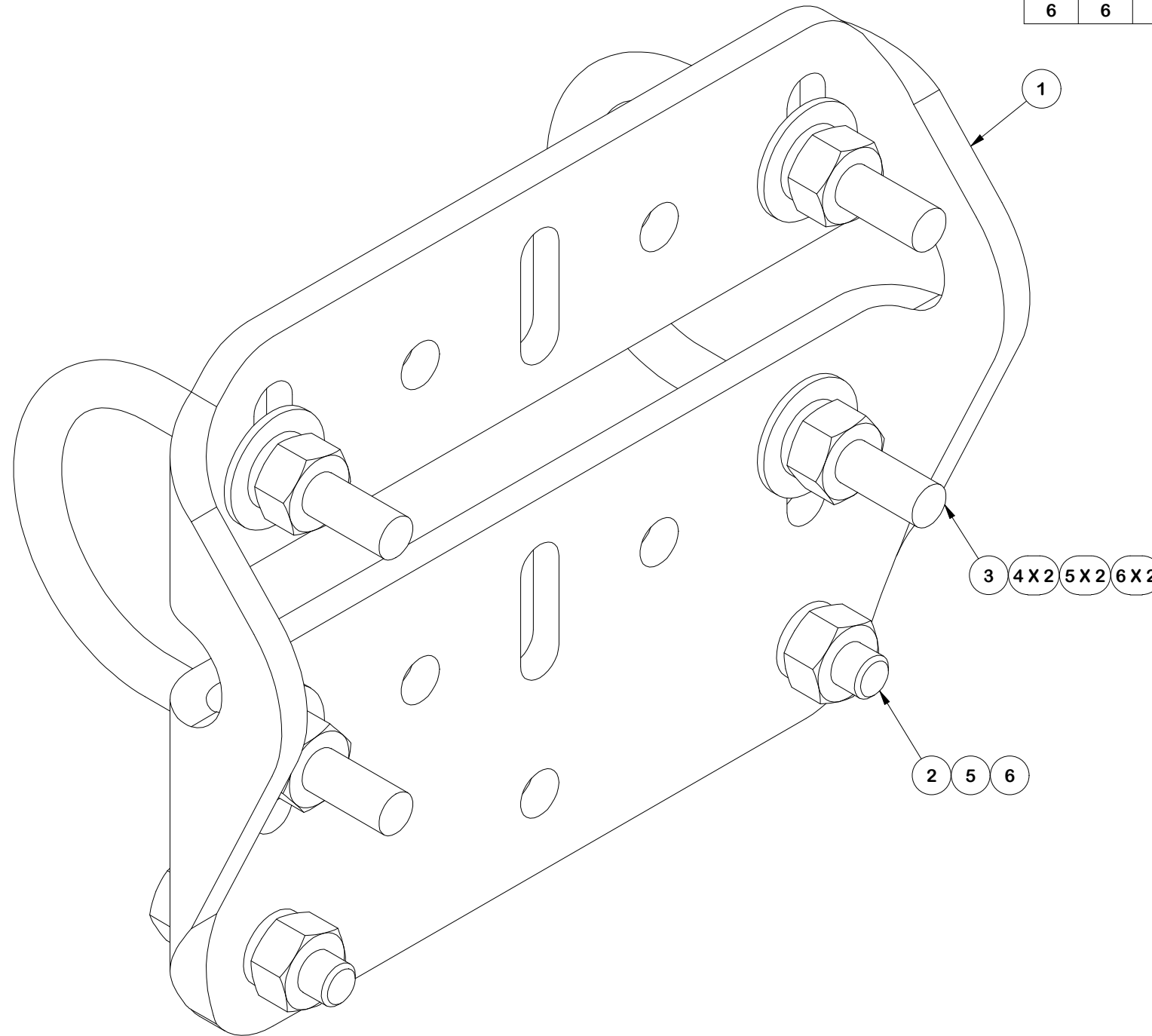

**FINISH:**  
HOT DIP GALVANIZED.

**TOLERANCE NOTES**

TOLERANCES ON DIMENSIONS, UNLESS OTHERWISE NOTED ARE:  
 SAWED, SHEARED AND GAS CUT EDGES ( $\pm 0.030"$ )  
 DRILLED AND GAS CUT HOLES ( $\pm 0.030"$ ) - NO CONING OF HOLES  
 LASER CUT EDGES AND HOLES ( $\pm 0.010"$ ) - NO CONING OF HOLES  
 BENDS AND ANGLES ARE  $\pm 1/2$  DEGREE  
 ALL OTHER MACHINING ( $\pm 0.030"$ )  
 ALL OTHER ASSEMBLY ( $\pm 0.060"$ )

PATENT INFORMATION: WWW.SITEPRO1.COM/PATENTS

PROPRIETARY NOTE:  
 THE DATA AND TECHNIQUES CONTAINED IN THIS DRAWING ARE PROPRIETARY INFORMATION OF VALMONT INDUSTRIES AND CONSIDERED A TRADE SECRET. ANY USE OR DISCLOSURE WITHOUT THE CONSENT OF VALMONT INDUSTRIES IS STRICTLY PROHIBITED.

DESCRIPTION  
**CSRT WIDE PIPE CLAMP BRACKET KIT**



Engineering Support Team:  
 sp1engineering@valmont.com

CPD NO.	DRAWN BY	ENG. APPROVAL
NCS	ADB 12/2/2024	12/2/2024
CLASS	DRAWING USAGE	CHECKED BY
87	CUSTOMER	CSL 12/2/2024

PART NO.	CSRT-PCBW
DWG. NO.	CSRT-PCBW